

GP-27

Direct type	Pilot type	Piston	Diaphragm
Bellows	Internal sensing	External sensing	Stainless steel
With handle	Built-in strainer	Low pressure	Remote
Valve leakage 0	Nylon		

■ Features

1. Large capacity and distinguished performance. Can respond very immediately to the fluctuation of inlet pressure and the change of flow rate to keep reduced pressure at a constant level.
2. Quite simple structure, less prone to fail and easy to handle.
3. Easy pressure adjustment and wide set pressure range.
4. No need for auxiliary power (air or electricity). Compactness makes plumbing work easy.
5. Compliant with SHASE-S106 Pressure Reducing Valves (by the Society of Heating, Air-Conditioning and Sanitary Engineers of Japan).



Pressure Reducing Valve

■ Specifications

Model	GP-27	
Application	Steam	
Inlet pressure	0.1-1.0 MPa	
Reduced pressure	0.03-0.8 MPa	
	80% or less of inlet pressure (absolute pressure)	
Minimum differential pressure	0.07 MPa	
Maximum pressure reduction ratio	10:1	
Maximum temperature	220°C	
Valve seat leakage	0.05% or less of rated flow rate	
Material	Body	Ductile cast iron
	Main valve, valve seat	Stainless steel
	Pilot valve, pilot valve seat	Stainless steel
	Piston, cylinder	Bronze
	Diaphragm	Stainless steel
Connection	JIS 10K FF Flanged	

· Available with trim parts (piston and cylinder) made of stainless steel.

■ Dimensions (mm) and Weights (kg)

Nominal size	L	H	H ₁	Weight
125A	375	627	162	90.0
150A	420	686	190	135.0
200A	490	765	220	204.0

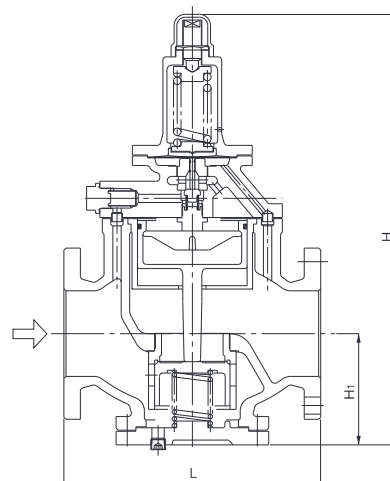

Specifications Selection Chart

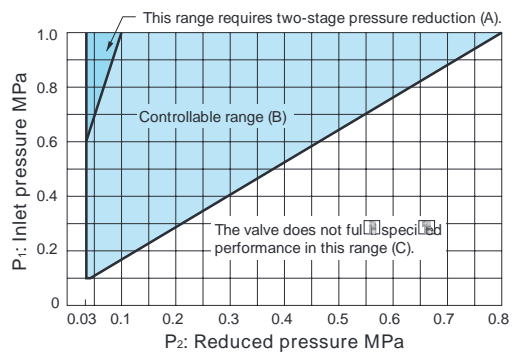

Pressure Characteristic Chart

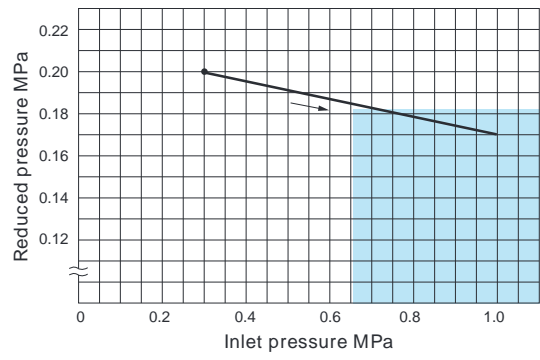

Based on the selection chart shown above, select a pressure reducing valve in the optimum manner. On the selection chart, find the intersection point of the inlet pressure (P_1) and the reduced pressure (P_2). Two-stage pressure reduction is required if the intersection point lies in range (A), or the pressures are controllable with a single pressure reducing valve if the intersection point is within range (B). The valve does not fulfill specified performance in range (C). To adopt two-stage pressure reduction, separate two pressure reducing valves as far away from each other as possible (preferably at least 3 meters).

This chart shows variation in reduced pressure when the inlet pressure of 0.3 MPa is changed between 0.3 MPa and 1.0 MPa while the reduced pressure is set at 0.2 MPa.

Flow Characteristic Chart

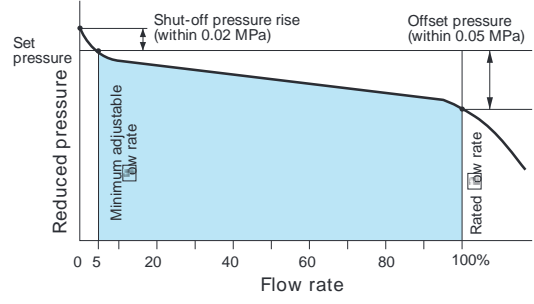

■ Nominal Sizes Selection Chart (For Steam)

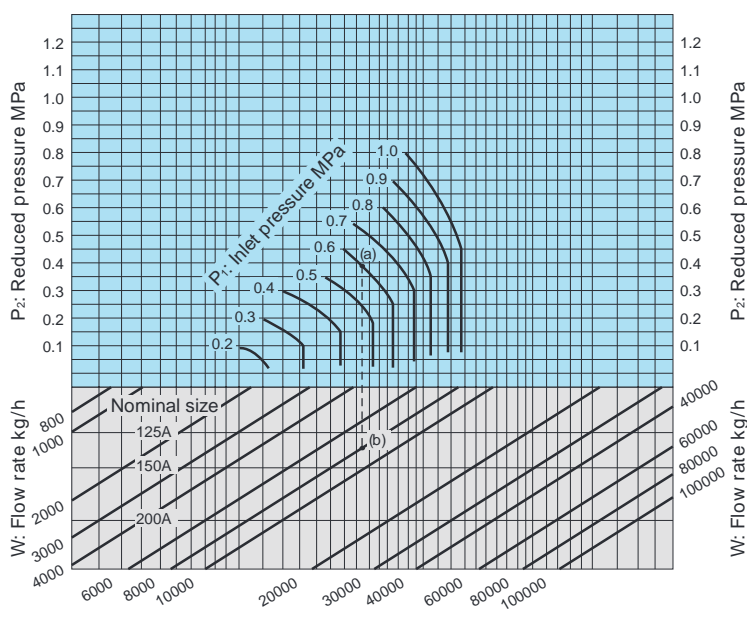

[Example]
When selecting the nominal size of a pressure reducing valve whose inlet pressure (P_1), reduced pressure (P_2), and steam flow rate are 0.6 MPa, 0.4 MPa, and 8000 kg/h, respectively, first find intersection point (a) of the inlet pressure of 0.6 MPa and the reduced pressure of 0.4 MPa. Trace down vertically from this intersection point to find intersection point (b) with the flow rate of 8000 kg/h. Since intersection point (b) lies between nominal sizes 125A and 150A, select the larger one, 150A.
* Set the safety factor at 80 to 90%.